

Adaptation of Positive Youth Development Sustainability Scale (PYDSS)

Ardiana Meilinawati^{1*}, Endah Mastuti¹

¹Airlangga University, Indonesia

*Corresponding author: Ardiana Meilinawati: ardmeilinawati@gmail.com



Citation: Meilinawati A., Mastuti E. (2020) Adaptation of Positive Youth Development Sustainability Scale (PYDSS). Open Science Journal 5(2)

Received: 1st May 2020

Accepted: 13th May 2020

Published: 3rd June 2020

Copyright: © 2020 This is an open access article under the terms of the [Creative Commons Attribution License](#), which permits unrestricted use, distribution, and reproduction in any medium, provided the original author and source are credited.

Funding: The author(s) received no specific funding for this work

Competing Interests: The author has declared that no competing interests exist.

Abstract:

This study aimed to determine the validity and reliability of the adaptation of Positive Youth Development Sustainability Scale (PYDSS). Positive Youth Development is an approach in the form of caring, supportive attitude, and tends to see adolescents as a source that must be developed to reduce the occurrence of behavioral problems (Nystrom, et al., 2008). There are five aspects of PYD or called the 5 Cs Model of PYD consisting of character, competence, connection, caring, and confidence (Lerner, 2005). The five aspects encourage the emergence of the sixth aspect is contribution (Sieng, et al., 2018). The focus of this research lies in the development of measuring instruments through the adaptation of PYDSS as a means to see the validity and reliability of the items in the PYDSS measurement tools. This study involved 242 subjects with age categories 15-18 years. The research used a questionnaire consisting of 29 statement items. Quantitative data analysis techniques used are validity tests based on content using Content Validity Ratio (CVR) and Content Validity Index (CVI), validity tests based on internal structure using confirmatory factor analysis (CFA), and reliability tests based on homogeneity/internal consistency through Cronbach's coefficient alpha and construct/composite reliability (CR). The results of data analysis showed that the value of CVR almost met the minimum parameters of $0.952 < 0.99$ where the average (CVI) > 0.8 ; all loading factors > 0.5 except for items CH2, CN4, and HC1, and the suitability of the model that is quite fit with a value of $\chi^2 / df > 2$; SRMR < 0.1 ; RMSEA < 0.1 ; CFI > 0.8 ; TLI > 0.8 ; and p-value < 0.05 . Reliability test through the Cronbach's alpha coefficient shows a number > 0.9 and CR value > 0.7 . This shows that the adaptation of PYDSS measurement tools fulfils good validity and reliability values.

Keywords: Positive youth development, adaptation of measurement tools, high school youth

Introduction

Measuring instruments that are classified as valid and reliable are needed in revealing a person's psychological aspects. This measuring instrument is also called a psychological measurement tool, psychological test, or psychological scale (Azwar, 1996). To achieve the validity and reliability of psychological measuring instrument, a systematic activity is carried out called the development of psychological measuring tools (Suryabrata, 2005). Development of psychological measurement tools is the process of producing measurement tools related to aspects in an individual by developing questions or assignments and combining them to become a test (Plake, et al., 2014).

In the process, the development of measuring instruments must pass several standards as stated in the book *Standards for Educational and Psychological Testing* (2014). In these guidelines, the standard development of psychological measuring instruments begins with the existence of test specifications, item testing, test evaluation, test administration, and scoring (Plake, et al., 2014). When a psychological measurement tool is used in various languages, it is necessary to make adjustments to the intended context. Plake et al. (2014) describe this process as an adaptation of measurement tools namely changes in content, format, and test administration to provide accessibility to all individuals with different characteristics.

Santrock (2014) states that each individual has different characteristics or uniqueness besides being a human being through a similar path of change. This change, which began at the time of conception and continues throughout human life, is known as developmental period such as prenatal, infancy, childhood, adolescence, adulthood, and old age (Santrock, 2014). In measuring this developmental period many psychological measurement tools have been developed according to its aspects such as three of them namely the Stanford-Binet test to measure cognitive abilities, the Big-Five Personality test to determine personality, and the Rothwell-Miller Interest Blank test to measure a person's interest. Not only cognitive abilities, personalities, and individual interests, the development of measurement tools is also carried out in measuring the overall development of individuals in accordance with existing aspects. One of the development of psychological measures referred to is the Positive Youth Development Sustainability Scale (PYDSS) from the research of Sieng, et al. (2018).

Positive youth development (PYD) is a branch of positive psychology that emphasizes the strengths and qualities of adolescents in accordance with the path of their development (Benson & Scales, in Santrock, 2014). PYD is defined as an approach that sees adolescents as an asset that must be developed based on the strengths owned rather than the source of the problem to be solved (Sieng, et al., 2018). Starting in the early 1990s, PYD developed into an approach used to reduce adolescent behavior problems (risk behaviors) by emphasizing interactions between adolescents and the surrounding environment including family, peers, and society (Nystrom, et al., 2008). The importance of family, peer, and environmental aspects also helps to increase PYD in adolescents. Lerner (2005) found that these aspects belong to the category of ecological assets which are

considered as predictors in supporting adolescent development. Teenagers who have a high score on PYD are predicted to be able to increase their ability to contribute to society. In addition, adolescents with high PYD levels also tend to have high levels of life satisfaction (Valickiene, 2015).

In measuring PYD, there is a model that guides the development of PYD measurement tools, namely 5 Cs Model of PYD. This model measures five dimensions namely competence, confidence, connection, character, and caring (Lerner, 2005). These five dimensions affect the sixth dimension, namely contribution. Research by Conway, et al. (2015) states that the 5 Cs Model of PYD is suitable as a model to measure PYD because the model is classified as fit on the data of adolescents aged 11-14 years and 15-19 years. There are many PYDs have been developed as a benchmark to see the tendency of adolescent development towards a positive direction abroad. Scores on each aspect become a reference in making PYD based youth development programs. These benchmarks can be seen from the PYD measurement tools developed including The Chinese Positive Youth Development Scale (Shek, 2006), Positive Youth Development Student Questionnaire (Lerner, et al., 2008), and The Bridge-Positive Youth Development (Lopez, 2015), and Positive Youth Development Sustainability Scale (Sieng, et al., 2018).

However, PYD measuring devices in Indonesia are still very minimal. There are 3 studies that raise PYD as an approach to encourage the development of adolescents and even children. The research is research "Guidance and Community Counseling to Support Positive Youth Development" (Rofi, 2015), "Positive Youth Development Program, Stimulators to Increase Competencies for Sexual Educators: A Documentation Study" (Repi, 2017), and "Factors Driving Development Positive Children: Review Studies of Traditional Games" (Syaukani & Subekti, 2018). In addition, the measuring instrument that researchers found was the Youth Development Index (IPP) which is a reference to see the level of youth development in Indonesia in the age range of 16-30 years. Theoretically, the age range is a mixture of adolescence with adulthood. Although the age range can be categorized as youth, but adolescents and adults have differences in their developmental tasks. IPP focuses on providing an indication of the progress of youth development based on its five domains, namely education, health and welfare, employment and employment opportunities, participation and leadership, as well as gender and discrimination (Bappenas, 2017). On the other hand, cases of adolescent behavior problems still occur in Indonesia. Behavioral problems that arise in the form of youth brawl actions are triggered by mutual challenges on social media (Maulana, 2019). There are also teenage students who carry out physical attacks on one of the cleaning services in their school (Widiyani, 2019). Not only that, one of the teenagers was reported doing a theft case (Utomo, 2018). There is also substance abuse that occurs in Surabaya where a group of teenagers get drunk due to inhaling the substances contained in glue (Salman, 2018). In addition, the most common problem in adolescents is the percentage of early marriage which reaches 44.7% (Rini & Tjadikijanto, 2018). PYD as an approach used in reducing behavior problems in adolescents is needed to handle these cases. Therefore, there is a need for a tool that can measure trends in adolescent development in individual contexts.

Responding to this, the researcher wanted to adapt the PYD measurement tools according to the context in Indonesia. Based on the previous explanation, there are 4 studies that discuss the 5 Cs Model of PYD as a valid and reliable measuring instrument. Lerner (2005) conducted a reliability test on the Positive Youth Development Student Questionnaire. The measuring instrument has an

internal consistency coefficient of 0.63-0.9 so that it belongs to a reliable measuring instrument. This measuring instrument was re-tested in a study conducted by Geldhof et al. (2013). The results show that the dimensions in the 5 Cs Model of PYD are acceptable and the items represent most of the models.

In addition, Lopez (2015) developed The Bridge-Positive Youth Development consisting of 40 items with a total of 140 subjects aged 7-18 years in the United States. The analysis shows that the Bridge-Positive Youth Development measurement tool is valid. Unlike the two previous measuring devices, Shek (2006) developed a PYD-based measuring instrument aimed at teenagers of Chinese ethnicity. The Chinese Positive Youth Development Scale (CYPDS) measures 15 aspects with 426 subjects. The results show that the CYPDS measuring instrument can be said to be valid and reliable for measuring adolescent development in Chinese culture.

However, these three measuring instruments have been tested in the United States and China so they need to be adapted to different contexts. The developed PYD measuring instrument has not measured the aspects of balance (sustainability) and happiness that represent the impact of PYD in the long run. This limitation drives Sieng, et al. (2018) to develop the Positive Youth Development Sustainability Scale (PYDSS) as a universal tool that can be used in various contexts. Sieng, et al. (2018) conducted PYDSS trials in Thailand and Phoenix, America. The results show that PYDSS is valid and reliable for use.

The uniqueness of PYDSS as a globalizing measuring instrument attracts researchers' interest to adapt to this measurement. The choice of Thailand as a country in the same regional region as Indonesia is an advantage of PYDSS measurement tools. Adaptation of the PYDSS measuring tool is carried out as an initial step in developing PYD measurement tools in Indonesia while proving the universality of PYDSS. Testing the validity and reliability of measuring instruments is needed to support or reject the assumptions of a construct that is theoretically expected to be measured by these users (Devena et al., 2013). Therefore, the adaptation of PYDSS measurement tools is also intended to find out the validity and reliability to see the development of Indonesian youth and as a basis for youth development programs to reduce adolescent behavior problems. Based on the above explanation, this study aims to determine the validity, reliability, and confirm the extract from the original Positive Youth Development Sustainability Scale (PYDSS) measuring instrument. The null hypothesis of this research is adaptation of the Positive Youth Development Sustainability Scale (PYDSS) is not considered valid and reliable.

Research methods and procedures

This study uses a quantitative approach that emphasizes analysis using numbers and numerical data and is processed by statistical methods (Azwar, 1996). In addition, this research develops measurement tools through the process of adapting measuring instrument to see their validity and reliability. This research is based on primary data collected through the provision of psychological measures to test participant/trial subjects. Conclusions are drawn from the figures as a result of processing data with statistical techniques. The variables in this study are the six aspects / constructs of PYDSS namely character, competence, contribution, connection, caring, and happiness / confidence. The

validity and reliability of the measuring instrument is assessed from the value of the items contained in the six variables.

PYD is defined as a trend towards adolescent development (Sieng, et al., 2018). The intended direction is positive or negative. This tendency is seen from the scores on the six aspects of PYDSS measurement tools. In this study, the PYDSS were tested for their validity and reliability in explaining the six aspects.

First, character is defined as adolescent knowledge related to good and bad things and how to do the right thing. The operationalization of the variable is based on the statement of the item in the aspect of character, "When I promise to do something, I can be counted on to do it" (CH1), "It is important for me to do the right thing" (CH2), "I can manage my emotions" (CH3), and "I like learning new things" (CH4).

Second, competence is defined as the ability of adolescents to work effectively in school and other social situations. Its operation is based on "I already knew what my goals were when I was an adult" (CO1) and "I have goals in my life" (CO2).

Third, contribution is explained as a positive contribution of adolescents to themselves, family, community, and the surrounding environment. Items / variables in this aspect are operationalized to the statement "It is important for me to try and make changes in the world" (CB1), "I have things that I can offer / give to others" (CB2), "I like to work together with others to solve a problem" (CB3), "I am a person who benefits others" (CB4), and "I take an active role in my community" (CB5).

Fourth, connection is a form of collaboration with teenagers with parents, peers, family, teachers, or members of the community that are followed by individuals. The operationalization of the item / variable is "I have close friendships" (CN1), "I have people I admire and respect (in my life" (CN2), "I feel close to my teachers" (CN3), "I feel close to my friends" (CN4), "My friends care about me" (CN5), and "I have many friends with a variety of different traits" (CN6).

Fifth, caring is how adolescents have a sense of affection and uphold social justice. The items are "I care about my friends' feelings" (CA1), "I can be relied on when someone needs my help" (CA2), "I try to encourage others when they are not as good as me in doing something" (CA3), "It's easy for me to understand other people's feelings" (CA4), and "When others need help, I help them" (CA5).

Sixth, happiness/confidence, that is, teenagers' trust in their abilities. The operationalization of the variables is in the item "I feel worthy / deserve something" (HC1), "I feel close to my parents" (HC2), "I feel satisfied with my life" (HC3), "I feel happy with people in my life" (HC4), "I am happy to join the community at school" (HC5), "I feel happy at school" (HC6), and "I feel happy at home" (HC7).

The subjects in this study were divided into two, namely the subjects included in the trial of measuring instruments and the final subject of the study. The trial subjects were 30 high school students in Surabaya aged 15-18 years. Subjects were instructed to fill in the answers to the measurement tools provided and provide an assessment related to the statement of the item that was unclear or could not be understood. This trial includes a discussion between the test giver (tester) and the test participant (testee). The results of these discussions form the basis for revisions before the final subject of the study is taken.

For the final subject of the study, sample size was taken based on a-priori sample size calculations in the study of structural equation models (SEM). From

the results of calculations based on Soper's online calculator (2019), this study used a sample of 242 people. In accordance with Myers, et al. (2011), the number of samples used is in the category of sufficient to do confirmatory factor analysis because it is in the range of 200 to 300 subjects. This sample also exceeds the minimum amount proposed by Brown (2015) and falls into a category that is sufficient according to the parameters of Comrey & Lee (1992).

This study uses survey techniques by distributing questionnaires as data collection instruments. Administration is done by providing a link to fill out the questionnaire via electronic devices. Subjects answered 29 items with 5 Likert scale choices of 1 (Strongly Disagree), 2 (Disagree), 3 (Neutral), 4 (Agree), and 5 (Strongly Agree). The data collection is carried out according to the stage of adaptation of measuring instruments (Sousa, et al., 2010) which are (i) review aspects/constructs of measuring instruments in accordance with the literature and request permission to the scale developer; (ii) translating (translating) measuring devices with forward and backward translation techniques; (iii) synthesizing the translation results based on forward and backward translation to find similarities and differences in the results of the translations using assessment of expert judgments, Content Validity Ratio (CVR), and Content Validity Index (CVI); (iv) testing the measuring instrument on a minimum of 10-40 subjects to ensure understanding related to the results of the translation of the measuring instrument; and (v) taking data on the final subject of research to conduct psychometric analysis in the form of validity and reliability tests.

The instrument used in this study was the Positive Youth Development Sustainability Scale (PYDSS) owned by Sieng, et al. (2018). This measuring instrument has two data namely from Thailand and Phoenix, United States. This study uses data sets from Thailand, amounting to 29 items from 6 aspects. The assessment was conducted with 5 Likert scale choices of 1 (Strongly Disagree), 2 (Disagree), 3 (Neutral), 4 (Agree), and 5 (Strongly Agree). All items in this measurement are stated to be universally used because the results of the construct validity of the loading factor are above 0.4 and Cronbach's alpha reliability is 0.951. For model compatibility, this measuring instrument is declared fit based on RMSEA, TLI, and CFI values.

This research analyzes the validity and reliability of measuring instruments. The process of measuring instrument adaptation validity is carried out using content validity and construct validity techniques. The validity of the content is done using the results of the assessment of expert judgments through the Content Validity Ratio (CVR) based on aspects of similarity, representativeness, and clarity in the item. The CVR results are averaged to get the Content Validity Index (CVI). In addition, validity is also carried out through confirmatory factor analysis (CFA) with accepted values (i) p-value > 0.05; (ii) χ^2/df value is between 2 until 5; (iii) Standardized Root Mean Square (SRMR) is near 0; (iv) Root Mean Square Error of Approximation (RMSEA) is near 0; (v) Comparative Fit Index (CFI) > 0.8; and (vi) Tucker Lewis Index (TLI) > 0.8 (Brown, 2015).

Measuring instruments are considered valid if they have a loading factor above 0.5 (Hair, 2010). In addition, the adaptation of measuring instruments also measures reliability through internal consistency attributes with the Cronbach's alpha method and construct / composite reliability (CR). If the Cronbach's alpha score is above 0.6 and the construct reliability (CR) is above 0.7, then the adaptation measuring instrument is considered reliable to use (Azwar, 2014). The analysis program used in this study is the IBM SPSS Statistics Subscription software, IBM SPSS Amos 26 for Windows, and Microsoft Excel 2007.

Discussion and interpretation of findings

Subjects in this study were obtained based on criteria established by the author, namely mid teens who were at the age of 15-18 years. The research subjects are high school students in Surabaya, which are spread in the administrative area of Surabaya. These include SMAN 3 Surabaya (North Surabaya), SMAN 19 Surabaya (North Surabaya), SMAN 12 Surabaya (West Surabaya), and SMAN 4 Surabaya (East Surabaya). Subjects were taken from classes X, XI, and XII in the science and social majors. Total subjects were 242 people which 63 people are male (26.1%) and 179 people are female (73.9%). There are 86 people who are 15 years old (35.5%), 102 people are 16 years old (42.1%), 47 people are 17 years old (19.4%), and the rest are 18 years old (2.9%).

Normality test

Normality test is one of the SEM assumptions including the measurement model that needs to be done in addition to the sample size and estimation methods of the model fit test (Santoso, 2018). The normality data of 242 subjects obtained as shown in Table 1.

Table 1. The result of normality test

Items	Mean	Standard Deviation	Skewness	Kurtosis
CH1	3,81	0,918	-0,715	0,807
CH2	4,41	0,880	-1,748	3,316
CH3	3,39	0,897	-0,126	0,099
CH4	4,05	0,858	-0,890	1,186
CO1	3,75	0,968	-0,418	-0,170
CO2	4,22	0,919	-1,355	2,074
CB1	4,05	0,841	-0,593	0,160
CB2	3,59	0,930	-0,377	0,225
CB3	4,01	0,897	-0,746	0,391
CB4	3,63	0,865	-0,065	0,060
CB5	3,49	1,003	-0,078	-0,462
CN1	4,31	0,882	-1,592	2,971
CN2	4,43	0,834	-1,782	3,726
CN3	3,49	0,785	0,028	0,405
CN4	4,14	0,861	-0,936	0,970
CN5	3,79	0,845	-0,290	-0,095
CN6	4,38	0,812	-1,400	2,124
CA1	4,08	0,889	-1,093	1,578
CA2	3,87	0,904	-0,593	0,449
CA3	4,16	0,832	-0,964	1,268
CA4	3,87	0,895	-0,550	0,288
CA5	4,09	0,792	-1,065	2,390
HC1	3,55	0,972	-0,277	-0,127
HC2	4,28	0,904	-1,095	0,573
HC3	3,61	1,001	-0,349	-0,135
HC4	4,14	0,875	-0,944	1,047

HC5	3,72	1,036	-0,419	-0,250
HC6	3,76	0,957	-0,583	0,436
HC7	4,12	0,980	-1,016	0,616

Based on the analysis result, the average value of skewness data is negative which means the form of data distribution tends to tilt to the right. On the average value of kurtosis, it was found that the value of kurtosis tends to be positive and pointed. It can be concluded that the data are not normal.

Validity test based on content

This study refers to Sieng, et al. (2018) where the authors adapted the Positive Youth Development Sustainability Scale (PYDSS). The validity calculation is based on a Content Validity Ratio (CVR) calculation. Calculations are based on a scale from 1 to 4. The CVR sheet is given to 7 expert judgments where the assessment is given based on the scale and provides written recommendations. The CVR analysis results show the data has a validity value between 0.761-0.952.

From the calculation results, 28 items can be said to almost meet the minimum value of the validity of all CVR showing coefficients above 0.95 where the minimum parameters are 0.99 (Lawshe, 1975). However, HC5 items are still far below the minimum value because the values are below 0.99, so the items are revised from “Saya bahagia mengikuti program di sekolah” to “Saya bahagia mengikuti komunitas di sekolah”

In addition to calculating the CVR, validity is also calculated based on the average value (CVI). The whole item on the scale is said to have good validity if the value is > 0.8 (Davis in Rubio et al., 2003; Polit & Beck, 2006). Based on the calculation of the formula, the CVI value on the adaptation of the PYDSS measuring tool is 0.919.

Validity test based on internal structure

The authors also use proof of validity based on internal structure through confirmatory factor analysis (CFA) to determine whether the results of the translation of a measuring instrument can explain aspects of the Positive Youth Development Sustainability Scale (PYDSS). The items on the measuring instrument are considered to be able to explain aspects of the measuring instrument if it has a loading factor value > 0.5 .

The analysis results show that all items reach a significance level with a p-value < 0.001 with a standardized loading factor and error value. It indicates that 26 items in the adaptation of PYDSS measuring devices can explain aspects of the measuring instrument well because it has a loading factor > 0.5 . However, 3 other items namely CH2, CN4, and HC1 have a loading factor value < 0.5 .

In addition, the validity of the adaptation of the PYDSS was also assessed based on a model compatibility test. This test is carried out to confirm the measurement model in the measuring instrument using the method of estimating the maximum likelihood (ML). To assess the model suitability index, Brown (2015) states that there are 4 indices recommended for use, namely Standardized

Root Mean Square (SRMR), Root Mean Square Error of Approximation (RMSEA), Comparative Fit Index (CFI), and Tucker Lewis Index (TLI)

Based on the analysis that has been done, the results show the SRMR value of 0.061; RMSEA value of 0.065; CFI value of 0.87; and TLI value of 0.854. This indicates that the PYDSS adaptation model is close to perfect fit based on SRMR and RMSEA values and good marginal fit based on CFI and TLI values. In addition, the level of significance (p-value) indicates a value below 0.05. However, some researchers do not recommend evaluating the model based on p-value because it is sensitive to the sample size so that it is replaced by the relative chi-square (χ^2 / df) which in Figure 1 is shown by the value of CMIN / DF = 2.301. Based on these results, the model has a pretty good match with values between 2 and 5 (Hooper, et al., 2008).

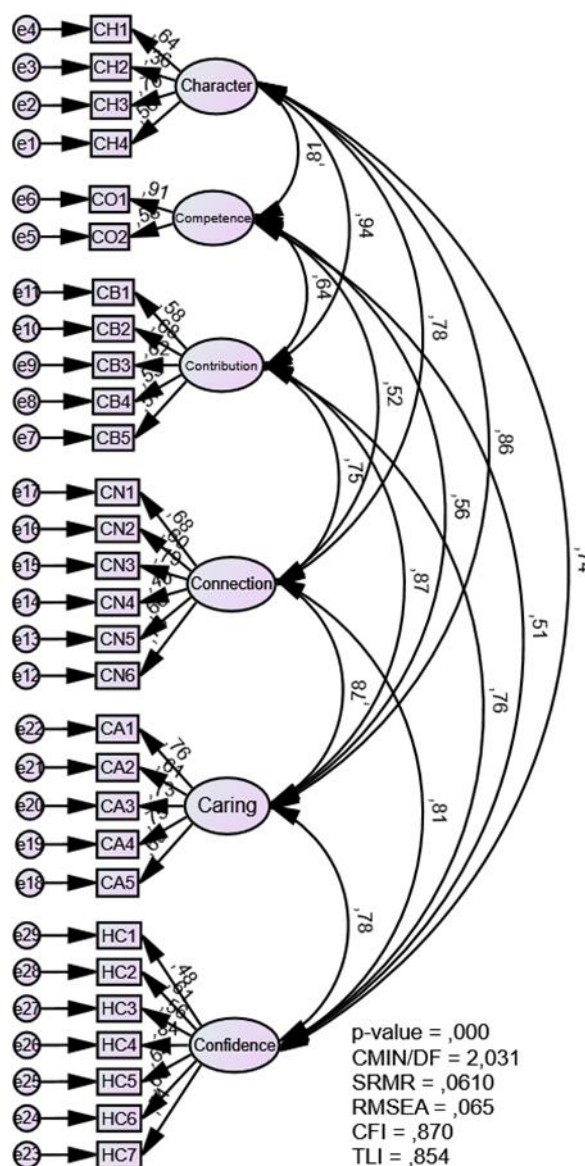

Figure 1. Model Fit Analysis Results

Reliability test based on homogeneity / internal consistency

To determine the reliability of PYDSS measurement adaptation, this study uses homogeneity attributes (internal consistency) through Cronbach's alpha calculation and construct/composite reliability (CR). The reliability test results show that Cronbach's alpha reliability value of 0.933 and construct/composite reliability (CR) ranging from 0.658 to 0.835. This shows that the PYDSS adaptation has good reliability except for the items on the character aspect which have a CR value < 0.7 . The conclusions of the analysis results from the validity test, reliability test, and model compatibility test can be seen in Table 2.

Table 2. Result of data analysis

	Analysis	Accepted Values	Results	Notes
Validity	CVI	$> 0,8$	0,761-0,952	Good
	CFA	$> 0,5$	0,359-0,906	Good
	p-value	$> 0,05$	0,00	Not fit
	χ^2/df	2-5	2,031	Fit
	SRMR	0-1	0,061	Marginal fit
	RMSEA	0-1	0,065	Marginal fit
	CFI	$> 0,8$	0,870	Marginal fit
	TLI	$> 0,8$	0,854	Marginal fit
Reliability	Cronbach's alpha	$> 0,6$	0,933	Good
	Construct Reliability (CR)	$> 0,7$	0,658-0,835	Good

Discussion

Positive Youth Development Sustainability Scale (PYDSS) developed by Sieng, et al. (2018) consists of 6 aspects which have 29 items. These aspects are called the 5 Cs Model of PYD namely character, competence, connection, caring, confidence, which then adds contribution aspects. The character aspect has 4 items consisting of CH1, CH2, CH3, and CH4 items. In the aspect of competence, there are 2 items, namely CO1 and CO2. While the contribution aspect has 5 items namely CB1, CB2, CB3, CB4, and CB5. Connection aspects have 6 items namely CN1, CN2, CN3, CN4, CN5, and CN6. In the caring aspect there are 5 items namely CA1, CA2, CA3, CA4, and CA5 while the confidence or happiness aspect has 7 items namely HC1, HC2, HC3, HC4, HC5, HC6, and HC7.

The analysis in this study consisted of validity and reliability tests. From the results of content validity test, 28 items can be said to almost meet the minimum validity value of all CVRs (Lawshe, 1975). However, HC5 items are still far below the minimum value because the value is below 0.99. This is caused by the translation results that do not have the same meaning as the original item. Four expert judgments suggest a translation change so that the writer changes from the statement "I am happy to join the program at school" to "I am happy to follow the community at school". This change was also made so that the statement is in accordance with the approach used by the makers of measuring instruments namely positive youth development where the community plays a major role in supporting the development of adolescents in a positive direction (Sieng, et al., 2018).

From the evidence of validity based on internal structure, the authors look at the value of the loading factor that each item has. Based on the results obtained,

the item that has the highest loading factor value is the CO1 item (0.906). This shows that the item "I have a purpose in my life" which has a strong connection with aspects of competence. This result also explains that the aspect of competence has a major contribution in knowing the tendency of adolescent development towards a positive direction.

In addition, items with the lowest loading factor are CH2 items (0.359), CN4 items (0.402), and HC1 item funds (0.475). The CH2 item that reads "It is important for me to do the right thing", the CN4 item that reads "I feel close to my friends", and the HC1 item that reads "I feel worthy / deserve something" is less able to explain aspects of character, connection, or confidence. In addition, the value of other loading factors satisfies the value of loading factors (standardized loading factors) above 0.5 so that the items in the adaptation of the PYDSS measuring device are related to the aspects and theories that underlie the measurement tools. In other sentences, these items can explain each aspect contained in the measuring instrument.

The analysis also shows a positive correlation between unobserved variables, which are 6 aspects contained in the measuring instrument. This correlation value ranges between 0.514-0.943. The highest value is found in the correlation between aspects of character and contribution. This explains that the higher the value in one aspect, the higher the value in other aspects correlated with that aspect. Theoretically, the contribution aspect is a behavior that describes the 5 Cs Model of PYD (Lerner, 2005). Adaptation of PYDSS in this study shows that the aspect of character has the strongest role in encouraging adolescent contributions. Indirectly, the formation of an important character in supporting the positive development of adolescents in a positive direction. Developments in the positive direction are supported by the contributions made by adolescents. This strong positive relationship between aspects of character and contribution supports the research of Lopez (2015) and Conway et al. (2015) that character has the most powerful role in determining the contribution of adolescents.

The validity of the measuring instrument was also tested through a model fit. The author uses a model compatibility test with Maximum Likelihood to find out whether the PYDSS adaptation has a model fit (model fit) with the model fitness criteria (goodness of fit). This is intended to prove whether the PYDSS adaptation model is in accordance with the six factor model analysis of the original measuring instrument. The results show that the PYDSS adaptation has a level of significance that is not good that is $p\text{-value} = 0.00$ in addition to other parameters that meet the goodness of fit criteria that is $\chi^2 / df = 2.301$; SRMR = 0.061; RMSEA = 0.065; CFI = 0.870; and TLI = 0.854. However, the $p\text{-value}$ has a high sensitivity to the number of subjects (sample size) so that when the number of subjects is greater then the $p\text{-value}$ will reach a significance level. Therefore, the smaller number of subjects, 242 people, is one of the limitations of the study that affects the $p\text{-value}$ of the model fit test.

After the validity test, the authors conducted a homogeneity reliability test through Cronbach's alpha coefficient and construct / composite reliability (CR). The results showed that 29 items had Cronbach's alpha values ranging from 0.929 to 0.933. Overall, the Cronbach's alpha value reached 0.933. While the calculation of construct / composite reliability (CR) results in reliability values ranging from 0.658 to 0.835. This shows that the PYDSS adaptation has a good reliability value except for the character aspect which has a CR value of less than 0.7. However, CR calculations using loading factor values affect CR results. The character aspect has a CR value of less than 0.7 caused by the item or CH2

factor with the lowest loading factor value. Based on this explanation, it can be concluded that PYDSS adaptation has good consistency when re-administrated.

From the results obtained, this study shows that the 5 Cs Model of PYD measurement model is proven to be valid and reliable so that it can be used universally. This is evidenced by valid and reliable results of measuring instrument development that have been tested before: Positive Youth Development Student Questionnaire (Lerner, 2008), The Bridge-Positive Youth Development (Lopez, 2015), The Chinese Positive Youth Development Scale (Shek, 2006), and Positive Youth Development Sustainability Scale (Sieng, et al., 2018). The adaptation results of the PYDSS measuring instrument with the original PYDSS measuring instrument also have the same results in terms of validity and reliability.

First, the loading factor values on the CH2 and HC1 items in the adaptation of the PYDSS measuring instrument to the original measuring tool are both under 0.5. In the original measuring instruments, the items have a loading factor value of 0.429 (CH2) and 0.431 (HC1). The results of this comparison show that the two items have not been able to explain aspects of both character and happiness / confidence so it is recommended to be reviewed.

Second, in the model fit test, the confirmatory factor analysis results in the adaptation of the PYDSS measuring instrument to the original measuring instrument also have similar values of CMIN / df, RMSEA, CFI, and TLI whose ranges are not much different. In the adaptation of PYDSS, CMIN / df = 2.301 while the original measurement was 2.334. At the RMSEA value, the adaptation of the PYDSS user reached 0.065 while the original measuring instrument was 0.057. For the CFI and TLI values, the adaptation of the PYDSS user reached 0.87 and 0.854 while the original measuring instruments were 0.93 and 0.933. These results indicate that both versions of the PYDSS measuring instrument have a good enough value of the model fit.

Third, in terms of reliability, the two versions of the measuring instrument both achieved a minimum value of Cronbach's alpha namely 0.929-0.933 on the adaptation of the PYDSS measuring instrument and 0.752-0.87 on the original measuring instrument. In fact, the adaptation of PYDSS users is classified as having better reliability than the original users.

However, it is inevitable that this study also has limitations and obstacles including (i) the location of the collection is quite far because it covers all four administrative areas of the City of Surabaya so that it takes a long time to collect data, (ii) the time of data collection which coincided with the final exam and preparation of the national exam for class XII so that the writer had to postpone several data collection schedules, (iii) inequality in obtaining a permit to collect data so that the author cancels a school because the letter administration process takes too long, (iv) the number of samples is not too much so that it affects the results of p-values that do not meet the criteria for model compatibility, (v) research only confirms the extract in the measuring instrument so that no modification is made to achieve a more fit model because there is no underlying literature or study, and (vi) the results of normality tests that do not meet the assumptions make this study only limited to testing the measurement model (measurement model), not to the structural model testing (structural model).

Conclusion

Based on the research conducted, it can be concluded that the adaptation of the Positive Youth Development Sustainability Scale (PYDSS) measuring tool in high school adolescents in Surabaya has evidence of validity based on internal content and structure as well as good reliability coefficient. Therefore, null hypothesis is rejected. Aspects / constructs in PYDSS measuring devices are found to be in accordance with the original PYDSS measuring devices through the results of a model fit which is quite fit. Overall, there are a number of suggestions below.

First, for further researchers, it is hoped that there will be an increase in the number of subjects so that the criteria for goodness of fit especially at the level of significance (p-value) can be achieved. In addition, there needs to be validity testing based on other sources, testing structural models if possible, and modifying the model if there is a basis for reference. Second, for users of PYDSS users, this research is expected to be used critically and carefully so that non-conformities with these users can be identified for further investigation. Adaptation of the PYDSS measurement tool can be used by taking into account the obstacles and limitations in this study.

Acknowledgements

Dra. Prihastuti, SU., Psikolog and Dr. Fitri Andriani, S.Psi, M.Si, Psikolog from Airlangga University for their excellent mentorship.

References:

- Azwar, S. (1996). *Tes Prestasi: Fungsi dan Pengembangan Pengukuran Prestasi Belajar*. Yogyakarta: Pustaka Pelajar.
- Azwar, S. (2014). *Reliabilitas dan Validitas*. Yogyakarta: Pustaka Pelajar.
- Bappenas. (2017). *Indeks Pembangunan Pemuda Indonesia 2017*. Jakarta: Kementerian Koordinator Bidang Pembangunan Manusia dan Kebudayaan Republik Indonesia.
- Brown, T. A. (2015). *Confirmatory factor analysis for applied research* (2nd edition). New York: The Guilford Press.
- Conway, R. J., Heary, C., & Hogan, M. J. (2015). An Evaluation of the Measurement Properties of the Five Cs Model of Positive Youth Development. *Frontiers in Psychology*, Volume 6, Article 1941, 1-13.
- Devena, S. E., Gay, C. E., & Watkins, M. W. (2013). Confirmatory factor analysis of the WISC-IV in a hospital referral sample. *Journal of Psychoeducational Assessment*, 31(6), 591-599.
- Geldhof, G. J. (2013). Creation of Short and Very Short Measures of Five Cs of Positive Youth Development.
- Hair, J. F. (2010). *Multivariate Data Analysis* (7th edition). New York: Prentice Hall International, Inc.
- Lawshe, C. H. (1975). A Quantitative Approach to Content Validity. *Personnel Psychology* Volume 28, 563-575.
- Lerner, R. M. (2005). Promoting Positive Youth Development: Theoretical and Empirical Bases. *The Science of Adolescent Health and Development* (pp. 1-91). Washington DC: National Academy of Sciences.
- Lopez. (2015). *Development and Validation of a Positive Youth Development Measure: The Bridge-Positive Youth Development*.
- Maulana, F. (2019, April 30). Tawuran Dipicu Aksi Saling Tantang di IG, Nyawa Pemuda di Jaksel Melayang. Retrieved from Detik.com: https://news.detik.com/berita/d-4531333/tawuran-dipicu-aksi-saling-tantang-di-ig-nyawa-pemuda-di-jaksel-melayang?_ga=2.247519367.1019593747.1556980894-1042185864.1553434371

- Myers, N. D., Ahn, S., & Jin, Y. (2011). Sample size and power estimates for a confirmatory factor analytic model in exercise and sport: a Monte Carlo approach. *Research Quarterly for Exercise and Sport*, Vol. 82 No. 3, 412-423.
- Nystrom, R. J., Prata, A., & Ramowski, S. K. (2008). Measuring Positive Youth Development: The Development of a State Benchmark. *Journal of Youth Development* Volume 3, Number 1.
- Plake, B. S., Wise, L. L., Cook, L. L., & etc. (2014). *Standards for educational and psychological testing*. Washington DC: American Educational Research Association.
- Polit, D. F., & Beck, C. T. (2006). The Content Validity Index: Are You Sure You Know What's Being Reported? Critique and Recommendations. *Research in Nursing & Health*, 29, 489-497.
- Positive Youth Development Program, S. t. (2017). Repi, Andhika Alexander. *Jurnal Experientia* Vol. 5 No. 1, 55-67.
- Ramdhani, N. (2012). Adaptasi Bahasa dan Budaya Inventori Big Five. *Jurnal Psikologi*, Volume 39, No. 2, 189-207.
- Rini, I. M., & Tjadikijanto, Y. D. (2018). Gambaran Program Generasi Bencana (GenRe) di Indonesia dan di Provinsi Jawa Timur Tahun 2017. *Jurnal Biometrika dan Kependudukan* Vol. 7, No. 2, 168-177.
- Rofi, A. (2015). *Bimbingan dan Konseling Komunitas Untuk Mendukung Positive Youth Development*. Bandung: Universitas Pendidikan Indonesia.
- Rubio, D. M., Berg-Werger, M., Tebb, S. S., Lee, E. S., & Rauch, S. (2003). Objectivizing content validity: Conduction a content validity study in social work research. *Social Work Research*, Vol. 27 No. 2, 94-104.
- Salman, G. (2018, November 14). 10 Remaja Mabuk Lem di Surabaya, Ini Tanggapan Risma. Retrieved from Kompas.com: <https://regional.kompas.com/read/2018/11/14/15321981/10-remaja-mabuk-lem-di-surabaya-ini-tanggapan-risma>
- Santoso, S. (2018). *Konsep Dasar dan Aplikasi SEM dengan Amos 24*. Jakarta: Elex Media Komputindo.
- Santrock, J. W. (2010). *Life-Span Development (Perkembangan Masa Hidup, Edisi Ketigabelas Jilid I)*. Jakarta: Penerbit Erlangga.
- Santrock, J. W. (2014). *Adolescence (15th edition)*. New York: McGraw-Hill Education.
- Shek, D. (2006). Development and validation of a positive youth development scale in Hong Kong. *International Journal of Adolescent Mental Health*, 547-558.
- Sieng, M., Cloutier, S., & Irimata, K. (2018). Positive Youth Developmental Sustainability Scale (PYDSS): The Developmental of an Assessment Tool. *Journal of Social Change* Volume 10, Issue 1, 81-97.
- Soper, D. S. (2019). A-priori Sample Size Calculator for Structural Equation Models [Software]. Retrieved from <https://www.danielsoper.com/statcalc/calculator.aspx?id=89>
- Sousa, V. D., & Rojjanasrirat, W. (2010). Translation, adaptation and validation of instrument or scales for use in cross-cultural health care research: a clear and user-friendly guideline. *Journal of Evaluation in Clinical Practice*, 268-274.
- Suryabrata, S. (2005). *Pengembangan alat ukur psikologis edisi 3*. Yogyakarta: Penerbit ANDI.
- Syaukani, A. A., & Subekti, N. (2018). Faktor Pendorong Perkembangan Positif Anak: Studi Review tentang Permainan Tradisional. PGSD - POR UMS: *Mengembangkan Kompetensi Pendidik dalam Menghadapi Era Disrupsi* (pp. 97-110). Surakarta: Universitas Muhammadiyah Surakarta.
- Utomo, D. P. (2018, July 22). Anak di Bawah Umur Ini Dilaporkan Ayah Tiri Bawa Lari Motornya. Retrieved from detikNews: https://news.detik.com/berita-jawa-timur/d-4127444/anak-di-bawah-umur-ini-dilaporkan-ayah-tiri-bawa-lari-motornya?_ga=2.167019710.1264483574.1557120885-1042185864.1553434371
- Valickiene, R. P. (2015). The Role of Character, Confidence, and Connection on Contribution and Subjective Well-Being. 7th World Conference on Educational Sciences (pp. 265-270). Athens: Procedia Social and Behavioral Sciences.
- Widiyani, R. (2019, February 11). Viral Siswa Pukul Cleaning Service, Psikolog Singgung Kesalahan Pola Asuh. Retrieved from Detik.com: https://health.detik.com/berita-detikhealth/d-4423520/viral-siswa-pukul-cleaning-service-psikolog-singgung-kesalahan-pola-asuh?_ga=2.135402929.1019593747.1556980894-1042185864.1553434371